

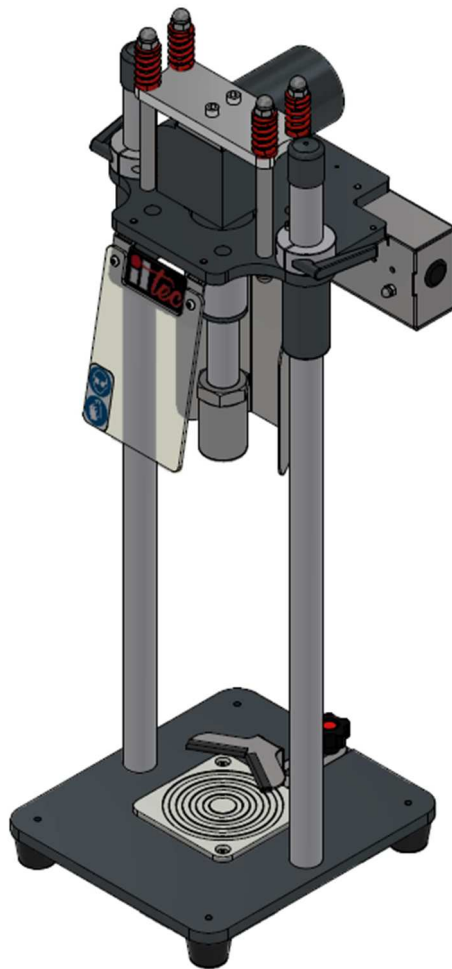

# User and Maintenance Manual

Original Instructions



UltraCapper Electric.

This USER MANUAL has been prepared in compliance with Directive  
2006/42/EC.  
Reproduction, even partial, is prohibited without the prior written authorization  
of ILTEC by I.L. INDUSTRIA di LEIVI Srl.



Via Gazzo, 1

16040 Leivi (GE)

T. +39 338 6616740

[www.il-tec.com/](http://www.il-tec.com/)

[sales@il-tec.com](mailto:sales@il-tec.com)

## Contents

<b>INTRODUCTION TO THE MANUAL</b> .....	3
<b>STORAGE OF THE USER INSTRUCTIONS</b> .....	3
<b>IDENTIFICATION DATA OF THE DEVICE</b> .....	3
<b>INTENDED USE</b> .....	3
<b>SAFETY INSTRUCTIONS</b> .....	4
<b>PACKAGE CONTENTS</b> .....	5
<b>UNPACKING</b> .....	5
<b>DESCRIPTION OF THE DEVICE</b> .....	5
<b>CARATTERISTICHE TECNICHE</b> .....	6
<b>HEIGHT ADJUSTMENT</b> .....	7
<b>BOTTLE STOP ADJUSTMENT</b> .....	8
<b>CHANGE OF CAP TYPE</b> .....	9
<b>WORKING CYCLE</b> .....	10
<b>CAPPING INSPECTION</b> .....	11
<b>Crown cap</b> .....	11
<b>Plastic mushroom cap</b> .....	11
<b>Press-fit not refillable cap</b> .....	11
<b>MAINTENANCE</b> .....	11
<b>TROUBLESHOOTING</b> .....	11
The electric actuator does not move .....	11
The upper block rises when capping the bottle .....	11
The bottles are not being capped correctly .....	11
The bottle gets stuck on the head.....	12
Bottle ejection with a dull noise .....	12
<b>SPARE PARTS</b> .....	12
<b>DISPOSAL</b> .....	12
<b>DICHIARAZIONE DI CONFORMITÀ</b> .....	13
<b>GARANZIA</b> .....	13

## INTRODUCTION TO THE MANUAL

This User and Maintenance Manual is a reference document prepared by the Manufacturer for operators who will handle the machine throughout its entire life cycle.

Its purpose is to provide all necessary information for correct use of the equipment—from installation to disposal—highlighting potential hazards resulting from improper use.

To achieve optimal results and ensure safety, the instructions contained in this Manual must be strictly followed.

## STORAGE OF THE USER INSTRUCTIONS

La mancata osservanza delle istruzioni di seguito riportate costituisce condizione di pericolo e pone a rischio l'incolumità del personale ed il corretto funzionamento della macchina.

This user manual is an integral part of the ULTRACAPPER capping machine and must be read carefully before use. It contains important information regarding safe installation, operation, and maintenance.

## IDENTIFICATION DATA OF THE DEVICE

The identification plate is located on the back of the device and contains the manufacturer's details and conformity to European Directives.



## INTENDED USE

ULTRACAPPER is designed for sealing different types of caps on glass bottles.

Any modification or replacement of components with non-original parts is strictly prohibited.

Improper or unintended use of the product is considered unsafe and releases the manufacturer from all liability.

Unintended use may cause damage to the equipment and serious personal injury. Any other use not intended for the product as designed and described in this document is considered non-compliant; therefore, the manufacturer disclaims all responsibility.

ILTEC by I.L. INDUSTRIA di LEIVI Srl shall not be held responsible for any damage to the machine and/or injury to personnel resulting from failure to comply with the safety instructions outlined in this Manual.

## SAFETY INSTRUCTIONS

Before using the ULTRACAPPER, carefully read the following general safety instructions.

- After removing the packaging, check the device for any damage. If in doubt, do not use it and contact ILTEC by I.L. INDUSTRIA di LEIVI Srl. Keep any packaging materials (plastic bags, cardboard, etc.) out of the reach of children or disabled persons, as they may pose a hazard. The safety concept of the device is valid only under perfect conditions.
- This device is not intended for use by persons (including children) with reduced physical, physiological, or intellectual abilities, or lack of experience and/or knowledge, unless they are supervised by a person responsible for safety or given instructions on how to use the device.
- Place the device on a dry and stable surface.
- To ensure sufficient ventilation, leave at least 12 cm of free space around the device.
- Do not expose the device to direct sunlight, wind, rain, or water splashes.
- Do not obstruct the device with objects while it is in operation.
- Disconnect the air supply before cleaning the device.
- Do not use metal sponges or abrasive products to clean the device.
- Supervise children to ensure they do not play with the "UltraCapper" stapler.
- The device is intended for domestic use and similar environments (workplaces, hotels, motels, and similar facilities). It is not for industrial use.
- Leave the repair or replacement of damaged or malfunctioning devices to customer service.
- Do not tamper with the device, as this may compromise its safety and void the warranty.
- Never immerse the device in water or other liquids; clean it only with a slightly damp cloth.
- Never leave the device switched on unattended.
- Use the device in environments with temperatures between 10°C and 35°C and humidity below 60%.
- Keep hands away from moving parts while the device is operating.
- **During adjustment and operation, wearing protective gloves according to EN 388:2016 (2121X) is mandatory.**
- **During operation, wearing protective goggles according to EN160 (1F) is mandatory.**
- Do not use the device if it is damaged.

The original configuration of the device must not be altered under any circumstances. Upon receipt, check that the delivery matches the order specifications. In case of non-compliance, immediately inform the manufacturer.

Also, verify that the device has not been damaged during transport.

Industria di Leivi products are not designed to operate in environments with explosion hazards or high fire risk. In case of malfunctions or improper operation, the devices must not be used until the Technical Support Service has completed the repair.

## PACKAGE CONTENTS

The packaging contains:

- UltraCapper Electric capping machine
- Ø26 crown cap head (pre-installed)
- Ø29 crown cap head
- Head for plastic mushroom and anti-refill caps

## UNPACKING

Open the box and remove all components. Ensure all parts are present and intact. Keep plastic bags away from children to avoid suffocation hazards.

## DESCRIPTION OF THE DEVICE

The device consists of the following main components:

1. Electric actuator
2. Splash guard
3. Column
4. Bottle support plate
5. Base
6. Guide bushing
7. Capping head (Ø26, Ø29, Mushroom caps)
8. Locking collar
9. Push button
10. Connector
11. Power supply
12. Power cable
13. Stop bracket
14. Stop fastening knob



Figura 1. Componenti

## CARATTERISTICHE TECNICHE

Power supply	220V/110V 50/60Hz
Dimensions	280x280x630
Power	60W
Weight	16.6 Kg
Protection rating	IP61
Max bottle diameter	150 mm
Max bottle height	380 mm

## INSTALLATION.

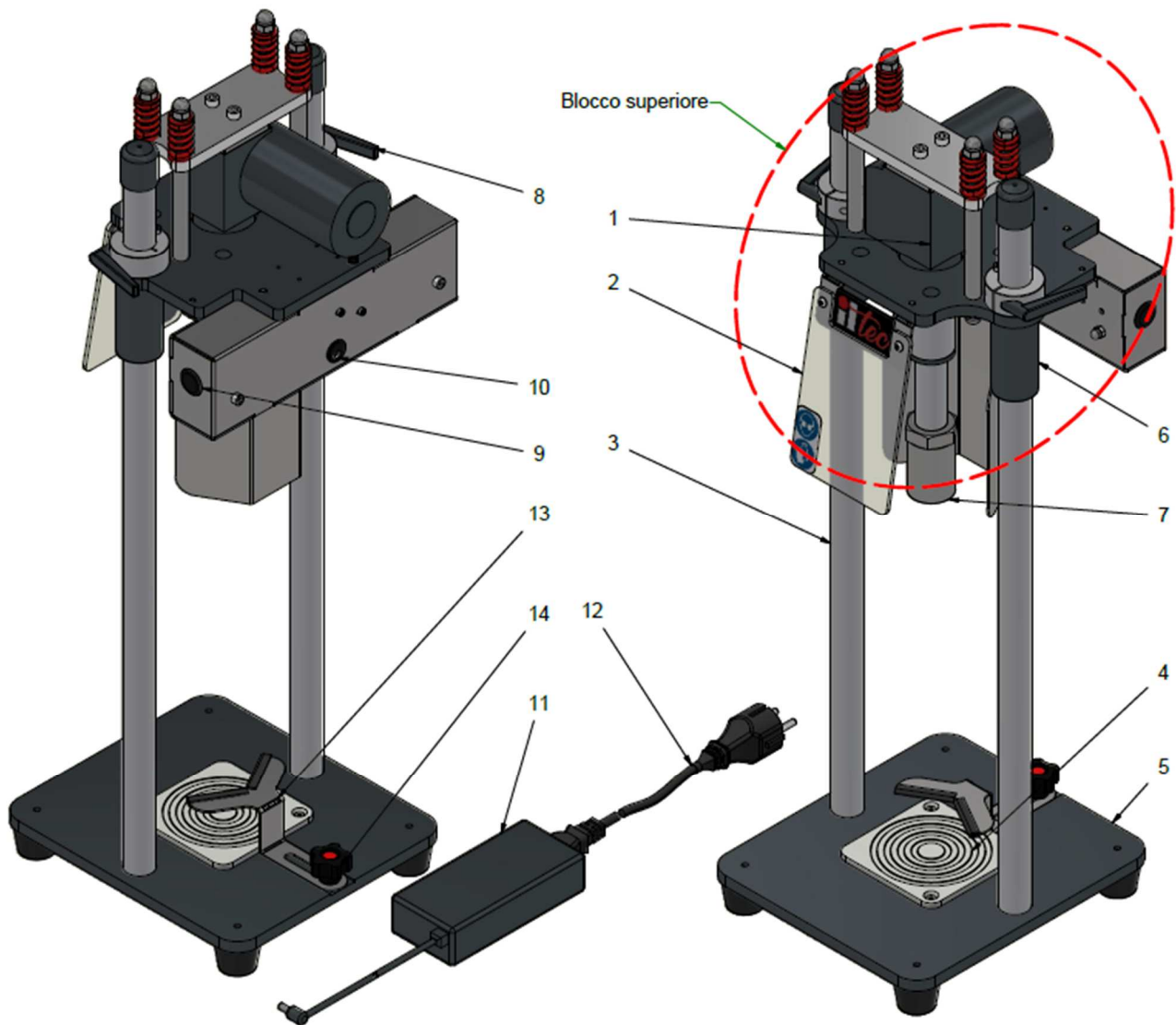
1. Place the capper on a flat surface, away from heat sources.

Before connecting the device to a power source, check that your supply voltage matches the value indicated on the device's nameplate.

2. Connect the device to the power supply using the cable provided.

## HEIGHT ADJUSTMENT

**The use of protective gloves in accordance with EN 388:2016 (2121X) is mandatory**

1. Ensure that the compressed air is disconnected.
2. Hold the upper block (see Figure 1) using the sliding bushings to prevent it from falling.
3. Loosen both collars (**turn counterclockwise**) until the upper block (see Figure 1) of the machine can move.
4. Lift the upper block of the machine to a position that allows easy placement of the bottle.
5. Insert the bottle and position the upper block so that there is 1 to 2 cm between the capping head and the top of the bottle.
6. Tighten both collars (**turn clockwise**).



Figura 2. Regolazione altezza

## BOTTLE STOP ADJUSTMENT

**Wearing protective gloves in accordance with EN 388:2016 (2121X) is mandatory.**

1. Loosen the knob (14) (turn counterclockwise) and move the stop bracket (15) all the way back.
2. Place the bottle in the center of the bottle support plate (4), ensuring it is perfectly aligned with the capping head.
3. Move the stop bracket (15) until it contacts the bottle.
4. Tighten the knob (14) (turn clockwise).

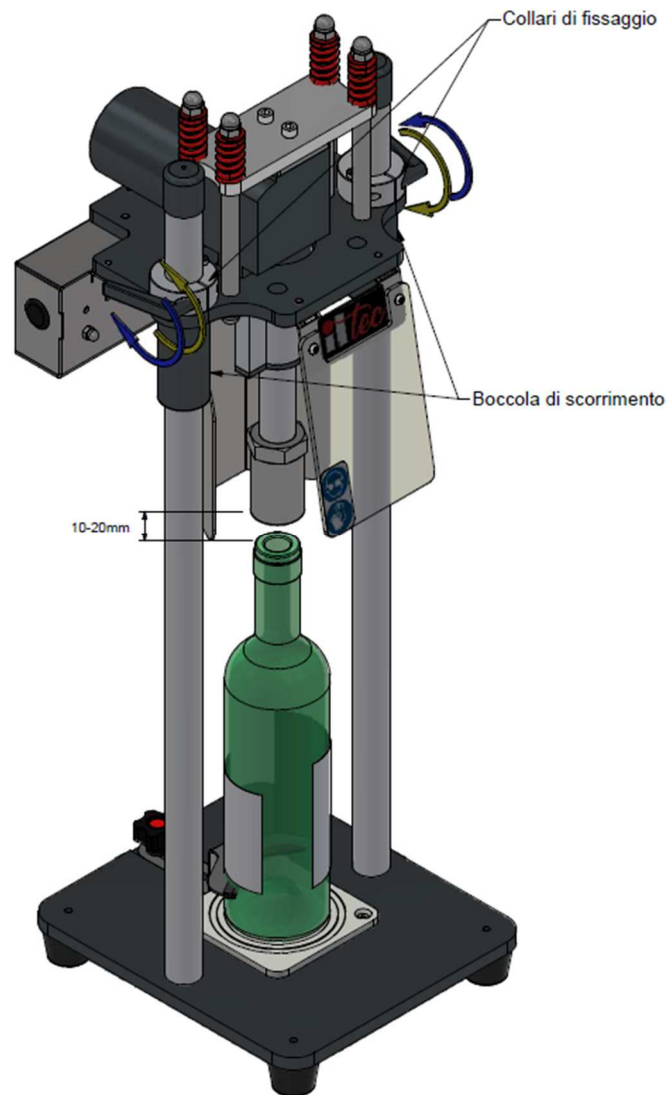
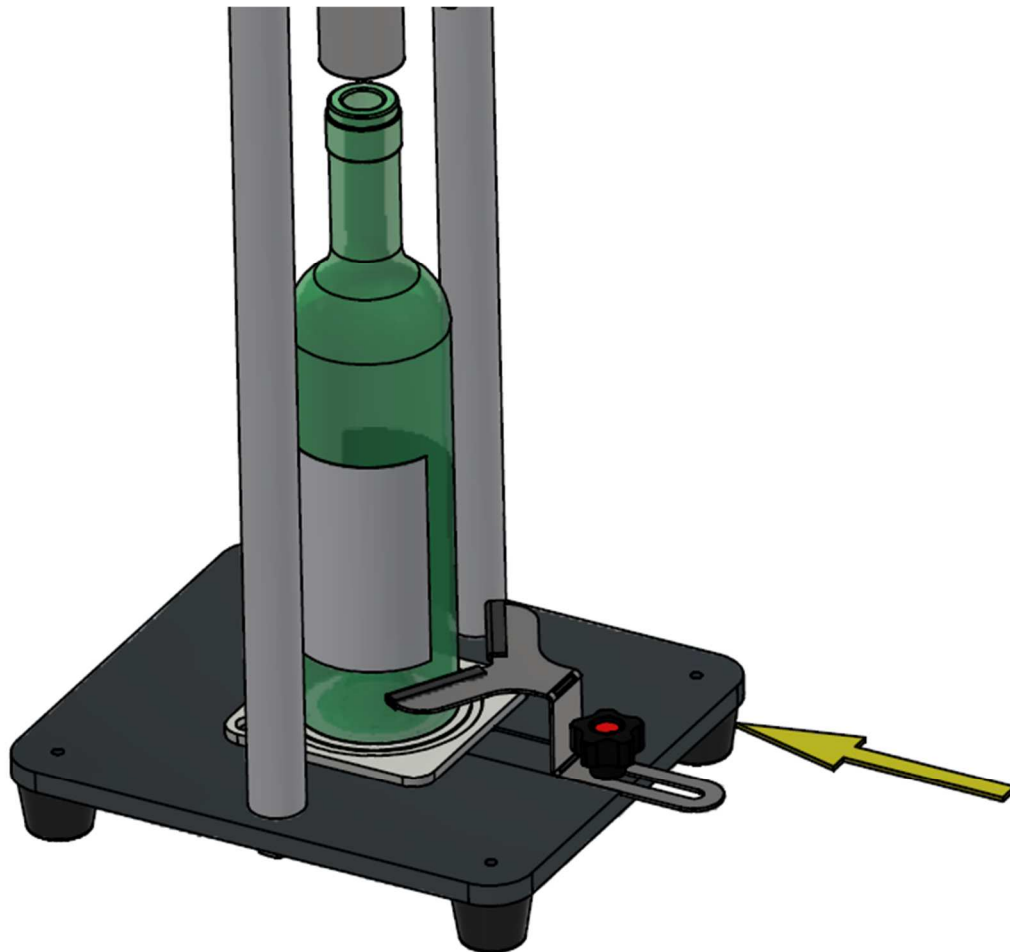



## CHANGE OF CAP TYPE

The device can process four types of caps:

- Crown cap Ø26
- Crown cap Ø29
- Plastic mushroom cap
- Press-fit not refillable cap

Depending on the type of cap to be processed, it is necessary to change the capping head (included in the supply). Below are the heads to be installed according to the type of cap to be processed.

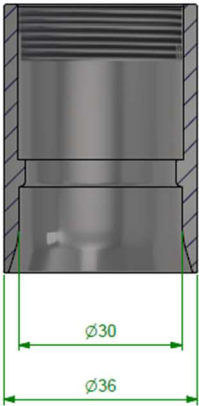
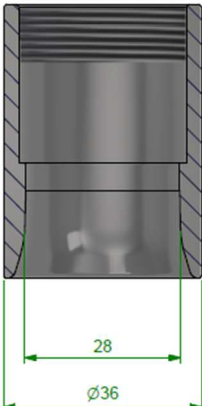
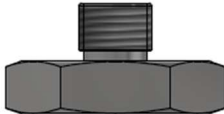
Crown cap Ø26	Crown cap Ø29	Plastic mushroom cap Press-fit not refillable cap
		
		

**The UltraCapper capping machine is not suitable for cork or screw caps.**

**Ensure that the cap is appropriate for the bottle you intend to cap. Using an unsuitable cap may damage the machine, break the bottle, and compromise user safety.**

## WORKING CYCLE

It is recommended to lubricate the inside of the cap with grease to facilitate the removal of the bottle.

**Any type of food-grade lubricant grease is suitable.**

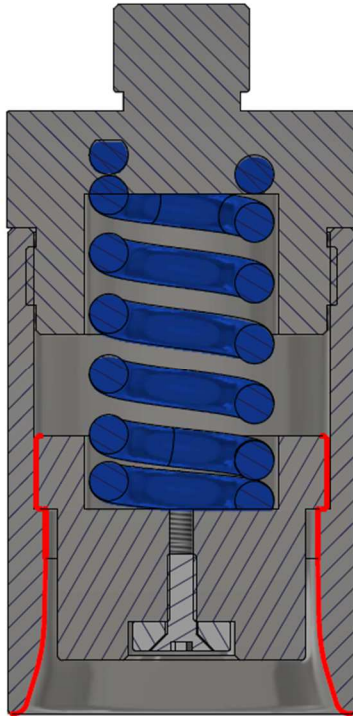

*Apply an even layer of lubricating grease to all surfaces indicated in red, making sure to cover them thoroughly to ensure effective and long-lasting lubrication.*

After connecting the device, installing the head according to the type of cap, and making the necessary adjustments, it can be operated.

**Wearing protective goggles in accordance with EN160 (1F) is mandatory.**

**Wearing protective gloves in accordance with EN 388:2016 (2121X) is mandatory.**

To perform a work cycle, proceed as follows:

- Insert the cap; for crown caps, place it on the head, where a magnet will hold it in position. For mushroom and press-fit anti-theft caps, place them on the neck of the bottle.
- Position the bottle in alignment using the previously adjusted stop as a reference (see page 8).
- Press both pneumatic valves simultaneously.
- At the end of the capping process, release both buttons and remove the bottle.

## CAPPING INSPECTION

### Crown cap.

For Ø26 crown caps, the diameter of the crown cap once sealed must be between 28.6 mm and 29.0 mm.

For Ø29 crown caps, the diameter of the crown cap once sealed must be between 31.4 mm and 31.8 mm.

- If the diameter is below the indicated values, the crown cap has been over-pressed. This may damage the bottle and cause rust and sealing problems.
- If the diameter is above the indicated values, the crown cap is not sufficiently sealed, which increases the risk of rust, sealing issues, and gas leakage.

### Plastic mushroom cap.

Visually inspect that the cap is fully seated on the bottle.

### Press-fit not refillable cap.

Visually check that the cap is securely fastened, not easily removable, and that the seal is intact.

## MAINTENANCE

Before carrying out any intervention, make sure that the filling machine is disconnected from the electrical power supply.

At the end of each use, all product residues must be removed. Then proceed to clean and thoroughly dry the machine, paying special attention to the head and its components.

After cleaning, apply grease to the heads to ensure optimal performance.

## TROUBLESHOOTING

### The electric actuator does not move

- Check that it is connected correctly, the button lights should turn on

### The upper block rises when capping the bottle

- Tighten both locking collars (8) more securely.

### The bottles are not being capped correctly

- Check that the pressure is between 5–6 bar.
- Check that the caps are suitable for the bottle.
- Check the height adjustment; the distance between the head and the bottle should be approximately 2 cm (see page 7).
- Check the alignment of the bottle with the capping head (see page 8).

### **The bottle gets stuck on the head**

- Check the inside of the head, clean it, and apply some grease (see page 10).

### **Bottle ejection with a dull noise**

- Check the inside of the head, clean it, and apply some grease (see page 10).

## **SPARE PARTS**

For the correct operation of the capping machine, it is recommended to use only original spare parts.

Upon request, the following can be supplied:

- Capping head (7)
- Switch (9)
- Electric actuator (1)
- Locking collar (8)
- Bottle support plate (4)

## **DISPOSAL**

If the product bears the symbol shown below (the crossed-out wheeled bin), the European Directive 2012/19/EU applies.

These products must not be disposed of with regular waste. Check the current regulations regarding the separate collection of electrical and electronic devices. Do not dispose of old devices with household waste. Proper disposal of old devices helps protect the planet and human health from potential negative effects. Recycling materials also helps reduce the consumption of raw resources.

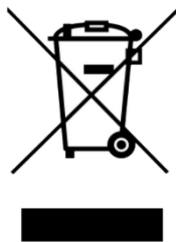

## DICHIARAZIONE DI CONFORMITÀ



**Manufacturer:** Industria di Leivi – Via Gazzo, 1 – 16040 Leivi (GE) – Italy

It is declared that the machine bearing the CE mark complies with the following Directives:

- UNI EN 574:1998

## GARANZIA

The warranty covers all material and manufacturing defects and provides for the replacement of spare parts or the repair of defective components exclusively through the dealer. In the case of a return for warranty repair, the customer is required to always send the “UltraCapper” capping machines complete to the dealer. Warranty repairs on individual faulty components will not be accepted.

The material sent for repair must be shipped **CARRIAGE PAID**.

After the repair, the device will be sent **CARRIAGE FORWARD** to the customer.

The warranty does not include the intervention of our technicians at the site of use of the “UltraCapper” machines, nor their disassembly.

The warranty excludes:

- Faults caused by incorrect use or assembly;
- Faults caused by external agents;
- Faults caused by negligence or poor maintenance.
- 

The warranty becomes void:

- In case of non-payment or other contractual breaches;
- If repairs or modifications are made to our devices without our consent;
- If damage is caused by incorrect use, or by mistreatment such as impacts, drops, or other causes not attributable to normal operating conditions;
- If the device has been disassembled, tampered with, or repaired by unauthorized personnel;
- If the devices are used for purposes other than those indicated in this manual.

Repairs carried out under warranty do not interrupt the duration of the warranty.

We thank you in advance for the attention you give to this manual and invite you to provide any suggestions you consider necessary to make it more complete.